

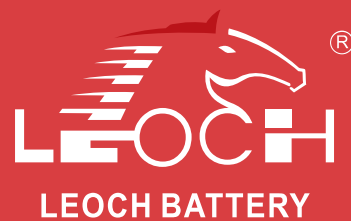

# LHR Series-High Rate

## LHR12215W(12V215W)



### Specifications

Rated Voltage	12V		
Nominal Rate ( $W_{15}, 1.67V/cell$ )	215W		
Nominal Capacity( $C_{10}, 1.80V/cell$ )	65Ah		
Dimension	Length	348±3mm (13.70 inches)	
	Width	167±2mm (6.57 inches)	
	Container Height	178±2mm (7.01 inches)	
	Total Height	178±2mm (7.01 inches)	
Approx. Weight	19.2 Kg (42.3 lbs)		
Terminal	T6(M6)		
Container Material	ABS: UL 94 HB or V-0		
Rated Capacity (25°C)	65.0 Ah	(10hr, 6.50A, 1.80V/cell)	
	62.4 Ah	(8hr, 7.80A, 1.80V/cell)	
	57.0 Ah	(5hr, 11.4A, 1.75V/cell)	
	51.6 Ah	(3hr, 17.2A, 1.75V/cell)	
	41.6 Ah	(1hr, 41.6A, 1.67V/cell)	
Max. Discharge Current	975A		
Internal Resistance (25°C)	Approx. 7.0mΩ		
Operating Temp. Range	Discharge	-20 ~ 55°C (-4 ~ 131°F)	
	Charge	-20~ 40°C (-4 ~ 104°F)	
	Storage	-15 ~ 50°C (5 ~ 122°F)	
Nominal Operating Temp. Range	25±3°C (77±5°F)		
Max. Charging Current(25°C)	16.25A		
Charge voltage(25°C)	Float	2.25 ~2.30V/cell	-3mV/cell/°C
	Equalization	2.30~2.40V/cell	-4mV/cell/°C
Effect of temp. to Capacity	40°C (104°F)	106%	
	25°C (77°F)	100%	
	0°C (32°F)	86%	
Self Discharge	≤3%/month @ 25°C		



### Layout

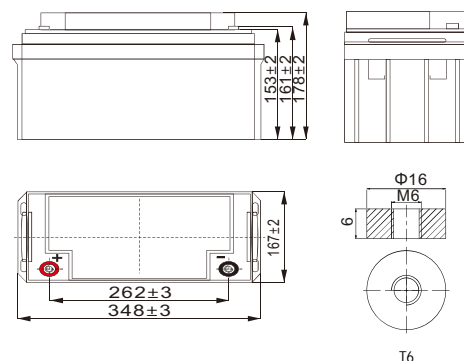

### Constant Current Discharge (Amperes) at 25 °C (77°F)

F.V/Time	5min	10min	15min	20min	30min	45min	1h	1.5h	2h	3h	4h	5h	8h	10h
1.85V/cell	135.3	101.0	84.1	70.7	54.3	40.5	34.2	25.7	20.6	15.5	12.4	10.3	7.29	6.09
1.80V/cell	157.7	119.1	97.8	81.4	61.4	45.3	37.9	28.1	22.4	16.8	13.3	11.1	7.80	6.50
1.75V/cell	172.1	127.7	103.5	85.5	64.2	47.2	39.3	29.0	23.1	17.2	13.7	11.4	7.94	6.60
1.70V/cell	186.4	136.2	109.4	89.9	67.0	49.0	40.7	30.0	23.8	17.7	14.0	11.6	8.08	6.70
1.67V/cell	194.6	141.2	112.8	92.5	68.7	50.1	41.6	30.6	24.2	18.0	14.2	11.8	8.17	6.76
1.60V/cell	214.5	152.8	120.9	98.5	72.6	52.7	43.6	31.9	25.2	18.7	14.7	12.1	8.36	6.91

### Constant Power Discharge (Watts/cell) at 25 °C (77°F)

F.V/Time	5min	10min	15min	20min	30min	45min	1h	1.5h	2h	3h	4h	5h	8h	10h
1.85V/cell	280.3	200.5	177.3	163.4	127.2	95.2	76.8	57.0	46.2	34.1	27.2	22.7	15.7	13.1
1.80V/cell	316.8	220.1	187.3	174.5	142.2	105.3	83.4	60.0	49.0	35.0	27.9	23.2	15.9	13.3
1.75V/cell	341.5	240.6	197.1	183.3	147.0	108.2	86.1	63.7	50.4	35.6	28.3	23.7	16.2	13.5
1.70V/cell	362.9	255.7	206.9	193.1	150.9	111.2	88.9	64.5	51.2	36.2	28.9	24.0	16.4	13.6
1.67V/cell	376.3	271.1	215.0	200.7	155.9	114.0	90.7	65.4	51.9	36.6	29.2	24.3	16.6	13.8
1.60V/cell	381.6	290.4	225.0	209.3	160.1	117.0	92.8	66.3	52.3	36.8	29.5	24.5	16.7	13.9



# LHR Series-High Rate

## LHR12215W(12V215W)



### Applications

- UPS
- Hospitals & Testing Laboratories
- Emergency Power Supply
- Industrial Process Control Facilities
- Banks & Financial Markets
- Data & Network Operation Centers

### General Features

- High quality AGM separator: extend cycle life and prevent micro short circuit
- PbCaSn alloy for plate grids: less gassing, less self-discharging
- Unique vent valve design: reduce water losing and prevent air/spark going inside

### Standards

- Compliance with IEC 60896 standards
- Classified as "Long Life" according to Eurobat
- CE, UL, IEC Certified
- Manufactured in Leoch@IATF16949, ISO 45001, ISO 9001 and ISO 14001 certified production facilities

### Discharge Characteristics

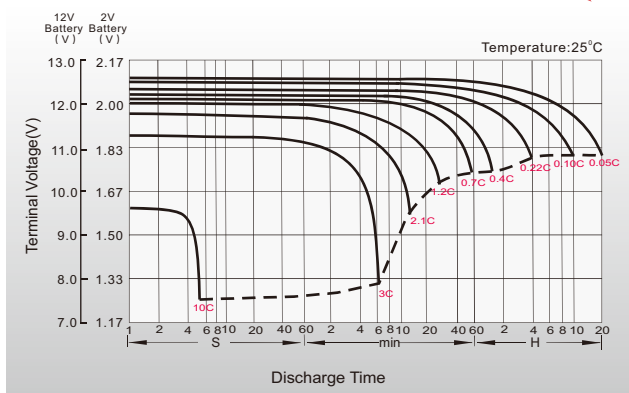

### Float Charging Characteristics

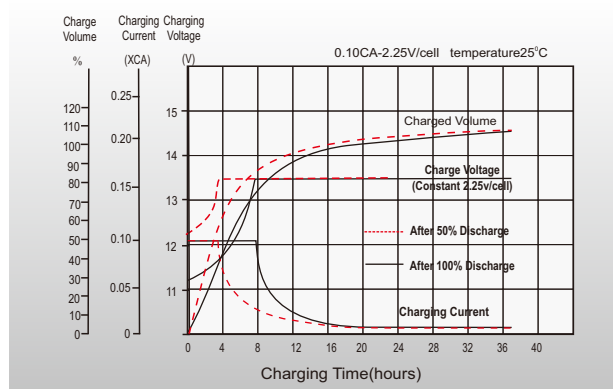

### Temperature Effects in Relation to Battery Capacity

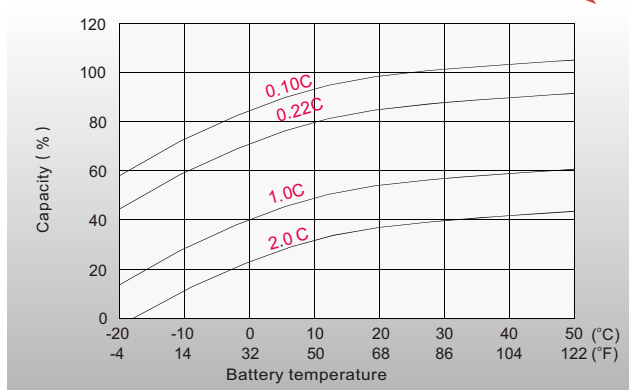

### Effect of Temperature on Long Term Float Life

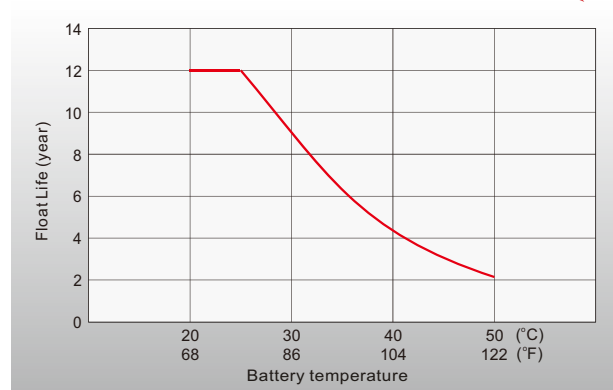

## Sales Offices Worldwide

#### China Sales Office

5th Floor, Xinbaohui Bldg., Nanhai Blvd.,  
Nanshan, Shenzhen, China. 518052  
Tel: +86-755-86036060 (100 lines)  
Fax: +86-755-26067269  
E-mail: export@leoch.com

#### HongKong Sales Office

Workshop C, 33/F, TML Tower, No. 3 Hoi Shing Road,  
Tsuen Wan, New Territories, Hong Kong  
Tel: +852 35786666  
Fax: +44 1452 690125  
E-mail: sales.hk@leoch.com

#### Singapore Sales Office

No. 1 Tech Park Crescent,  
Singapore 638131  
Tel: +65 68636078  
Fax: +65 6863 6079  
Email: sales.sg@Leoch.com

#### Australia Sales Office

2 /29 Tarlington Place, Smithfield. NSW 2164  
Australia  
Tel: 02 9756 0950  
E-mail: sales.au@leoch.com

#### North America Sales Office

19751 Descartes  
Foothill Ranch, CA 92610, USA  
Tel: 949-588-5853  
Fax: 949-588-5966  
E-mail: sales@leoch.us  
Http:// www.leoch.us

#### UK Sales Office

9B Wheatstone Court, Waterwells, Business Park,  
Gloucester, GL2-2AQ, UK United Kingdom  
Tel: +44(0) 1452 729428 / 1452 729696  
Fax: +44 1452 690125  
E-mail: Sales.Europe@leoch.com  
Http:// www.leoch.eu

#### EMEA Sales Office

1 Deligiorgi St., 121 31 Athens,  
Greece  
Tel: +30 210 5760318 (2 lines)  
E-mail: support\_EMEA@leoch.com  
Http:// www.leoch.eu

#### India Sales Office

Shed no. A-53(b), 2nd Stage of Peenya Industrial Area,  
Bangalore North Taluk, Bangalore-560058, India  
Tel: +91-80-23440018/23440019  
Fax: +91-80-23440017  
E-mail: indiasales@leoch.com



[Http://www.leoch.com](http://www.leoch.com)

© 2023 LEOCH. All rights reserved.

Trademarks and logos are the property of LEOCH and its affiliates unless otherwise noted.  
Subject to revisions without prior notice E&OE.

Publication No.: LB-LHR12215W-PD-EN-V1.4-202304